

Ketone Bodies as a Therapeutic for Alzheimer's Disease

Samuel T. Henderson

Accera, Inc., Broomfield, Colorado 80021

Summary: An early feature of Alzheimer's disease (AD) is region-specific declines in brain glucose metabolism. Unlike other tissues in the body, the brain does not efficiently metabolize fats; hence the adult human brain relies almost exclusively on glucose as an energy substrate. Therefore, inhibition of glucose metabolism can have profound effects on brain function. The hypometabolism seen in AD has recently attracted attention as a possible target for intervention in the disease process. One promising approach is to supplement the normal glucose supply of the brain with ketone bodies (KB), which include acetoacetate, β -hydroxybutyrate, and acetone. KB are normally produced from fat stores when glucose sup-

plies are limited, such as during prolonged fasting. KB have been induced both by direct infusion and by the administration of a high-fat, low-carbohydrate, low-protein, ketogenic diets. Both approaches have demonstrated efficacy in animal models of neurodegenerative disorders and in human clinical trials, including AD trials. Much of the benefit of KB can be attributed to their ability to increase mitochondrial efficiency and supplement the brain's normal reliance on glucose. Research into the therapeutic potential of KB and ketosis represents a promising new area of AD research. **Key Words:** Alzheimer's disease, hypometabolism, ketone bodies, acetoacetate, β -hydroxybutyrate, glucose, insulin, apolipoprotein E, ketogenic diet.

INTRODUCTION

Alzheimer's disease (AD) (Online Mendelian Inheritance in Man 104300) is a progressive neurodegenerative disease that primarily afflicts the elderly. Risk of developing sporadic AD is principally linked to age and the carriage status of the epsilon 4 (E4) variant of the apolipoprotein E gene (APOE). Possession of one or more E4 alleles increases risk and lowers age of onset (for review, see reference¹). AD is clinically characterized by progressive decline in memory and language, and pathologically by accumulation of senile plaques and neurofibrillar tangles. Another prominent feature of AD is regional cerebral hypometabolism found in the posterior cingulate, parietal, temporal, and prefrontal cortex (for review, see reference²). This hypometabolism occurs early in the disease and may contribute to both the cognitive decline and the pathology associated with AD. Interventions targeting this metabolic defect may prove beneficial to the AD patient. One such intervention is to supplement the normal energy substrate of the brain with an alternative substrate that enhances metabolism.

BRAIN METABOLISM

The human brain is one of the most metabolically active organs in the body. Cerebral oxygen consumption for an average adult human is roughly 3.5 mL/100 g/min. For an average-sized brain of 1400 g, this is about 40 mL O₂/min. At rest, the average total oxygen consumption for a person is approximately 250 mL O₂/min. Therefore, the brain uses approximately 16% of the body's total O₂ consumed. This is remarkable in that the brain accounts for only about 2% of the total body mass. The pioneering work of Clarke and Sokoloff³ found that most of the oxygen in the brain is used for the oxidation of glucose to carbon dioxide and water. Under normal conditions, the only consistent arteriovenous differences across the brain are glucose and oxygen, and the contribution of fatty acids is considered minor. The average adult human brain will metabolize about 110 to 145 g/day of glucose. The brain is quite efficient in its metabolism of glucose. The theoretical ratio of oxygen/glucose use for the complete oxidation of glucose is 6. In practice the ratio is typically ~5.5, hence not all the glucose is oxidized and a portion is likely shunted toward synthesis pathways. Similarly, small amounts of oxygen are also used in other pathways, such as synthesis and degradation of monoamine neurotransmitters. Yet, most of the glucose (>90%) is oxidatively degraded for ATP synthesis (for review, see reference³).

Address correspondence to: Samuel T. Henderson, PhD, Accera, Inc., 380 Interlocken Crescent, Suite 780, Broomfield, CO 80021. E-mail: shenderson@accera.com.

Much of the energy derived from glucose may be used to fuel neuronal signaling from “default network” activity. Magnetic resonance spectroscopy tracing glucose oxidation, and glutamate and gamma-aminobutyric acid cycling has shown that as much as 80% of the glucose consumed is used in cycling these transmitters for neuronal signaling processes and not simply for housekeeping duties.⁴ Task-specific activation of regions of the brain increase local blood flow and glucose use, but when compared with the energy demands as a whole of the brain, such tasks consume little energy. Therefore, it has been proposed that much of the ATP generated is used by functional neuronal signaling that occurs at rest when no specific tasks have been activated, often referred to as the default network.⁵ The default network is believed to function in a variety of internal cognitive tasks that do not require outside stimuli, such as planning for the future and memory retrieval (for review, see reference⁶).

The brain depends largely on glucose in circulation for most of its function and stores little energy in the form of glycogen. It has been estimated that the glycogen stores of the brain provide only enough glucose for approximately 5 minutes of normal function.³ This is evident in cases in which blood glucose drops rapidly, such as administration of supraphysiological doses of insulin. Such precipitous declines in circulating glucose cause rapid deterioration in cognitive performance, confusion, and coma.⁷

Another more chronic example of the brain's reliance on glucose can be found in glucose transporter 1 (GLUT1) deficiency syndrome (GLUT1 DS, OMIM 606777). The two main glucose transporters in the brain are the facilitative transporters encoded by the *GLUT1* and *GLUT3* genes. The Glut1 protein is prominently expressed in the endothelial cells of the cerebral microvasculature and in the astrocyte footpads that contact the vasculature. Glut1 transports a large fraction of the glucose into the brain.⁸ Due to the high glucose requirements, both copies of the *GLUT1* gene are required for proper brain function. If one copy of the *GLUT1* gene is nonfunctional (haploinsufficiency), then glucose can not be adequately supplied to the brain. In GLUT1 DS, the typical cerebrospinal glucose concentrations are 30 to 40% of blood concentrations.⁹ Such low concentrations of glucose have profound outcomes on development and cognitive function. Clinical features of GLUT1 DS include: seizures, hypotonia, ataxia, language deficits, and microcephaly.¹⁰

GLUCOSE METABOLISM IN AD

A prominent and well-characterized feature of AD is progressive, region specific, declines in the cerebral metabolic rate of glucose (CMRglc). Early studies compar-

ing AD subjects with normal controls found a 17 to 24% decline in CMRglc across the whole brain. In addition, significant correlations between CMRglc and cognitive function were noted, such that low CMRglc correlated with low cognitive scores.¹¹ Numerous subsequent imaging studies have confirmed these observations. Abnormally low rates of CMRglc are found in a characteristic pattern in the AD brain, particularly in the posterior cingulate, parietal, temporal, and prefrontal cortex (see FIG. 1; for review, see reference²). This pattern is reproducible and has been proposed as a diagnostic tool for AD.^{12,13} Interestingly, regions of the brain showing hypometabolism significantly overlap with regions identified in the default network. Furthermore, it has been suggested that the high levels of glucose utilization in these area may be conducive to the future development of hypometabolism, plaque deposition, and cell atrophy that characterizes AD.¹⁴

The regional reductions in CMRglc in AD may be due to reduction in the density or activity of terminal neuronal fields or glial cells, a metabolic defect within neurons or glia, or a combination of these factors. In a series of experiments, Reiman et al.¹⁵ examined the onset of hypometabolism in nondemented subjects at risk for AD. In an early study, Reiman et al.¹² screened subjects between the ages of 50 and 65 years of age with a family history of AD for those who were homozygous for the E4 allele, and therefore at high risk of developing AD. Eleven E4/E4 participants (mean age, 55.4) were identified and compared with 22 matched controls (mean age, 56.3). The homozygotes and controls did not differ in any cognitive test, yet the E4/E4 homozygotes showed declines in glucose metabolism in the same regions identified in AD subjects.¹² In a follow-up study examining young adults,¹⁵ 12 E4 carriers (E4/E3) were compared with 15 E4 noncarriers. Similar to the previous study, E4 carriers (E4(+)) were found to have low CMRglc bilaterally in the posterior cingulate, parietal, temporal, and prefrontal cortex, despite showing no signs of cognitive impairment. The mean age of the E4 carriers was 30.7 years. The authors conclude that “Carriers of a common Alzheimer's susceptibility gene have functional brain abnormalities in young adulthood, several decades before possible onset of dementia.”¹⁵ Therefore, low regional CMRglc appears to be a very early event in the disease process, well before any clinical signs of dementia are evident, and well before cell loss or plaque deposition is predicted to have occurred (FIG. 1).

Regional low CMRglc is not exclusive to E4 carriers. Corder et al.¹⁶ examined 46 patients in a memory disorder clinic. Thirty one of these patients were diagnosed with probable AD, of these: 16 were E3/E4, 11 were E3/E3, and were 4 E2/E3. These 31 subjects demonstrated a mean 11% decline in CMRglc in the frontal region and a 27 to 31% decline in the temporo-parietal

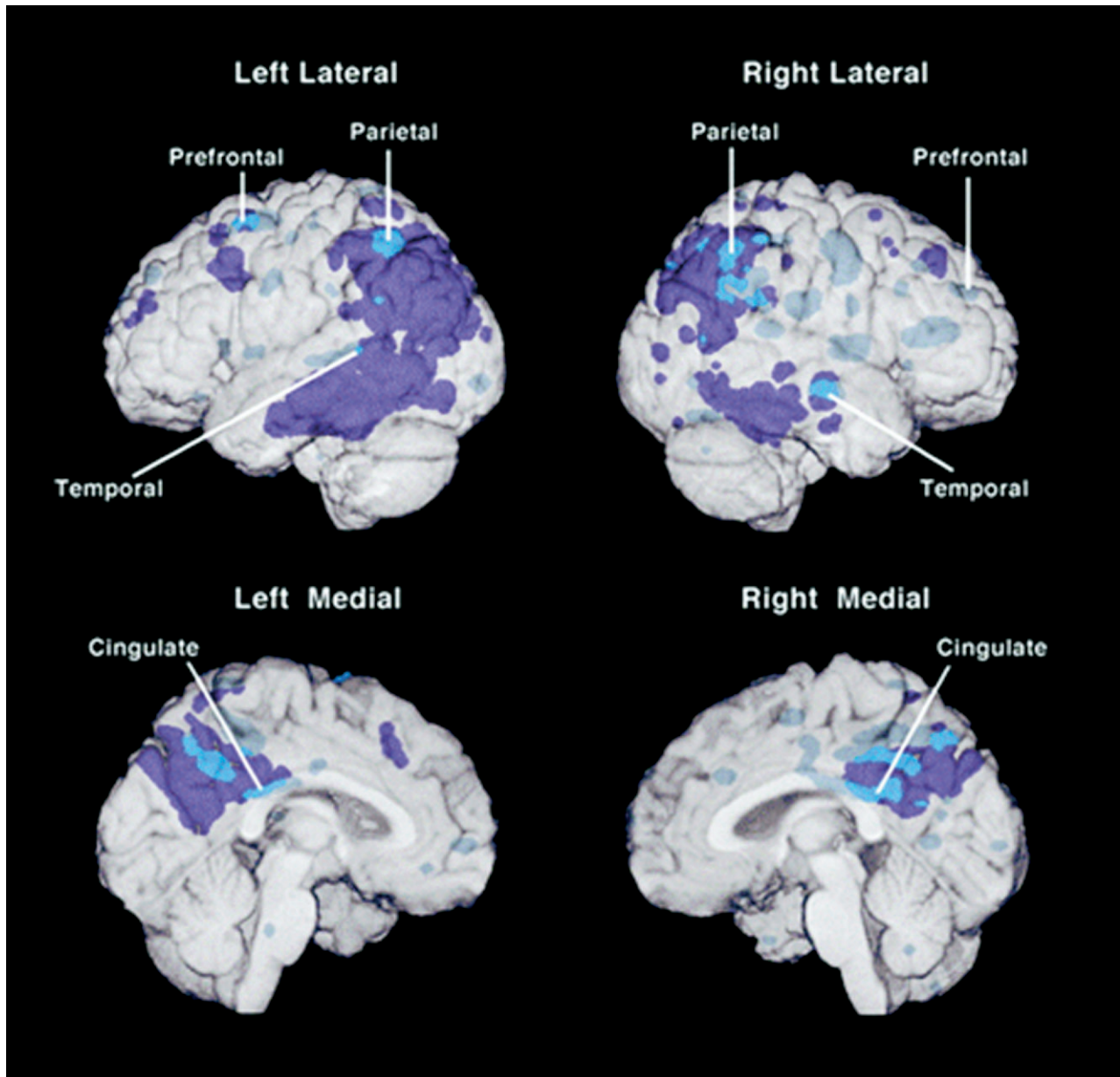

FIG 1. Regional hypometabolism is an early and progressive feature of Alzheimer's disease (AD). Shown is a three-dimensional surface projection map of abnormally low cerebral metabolic rate of glucose (CMRglc) in the young adult E4 carriers (bright blue regions) superimposed on a map of abnormally low CMRglc in patients with the probable AD (purple regions) mapped to a volume-rendered magnetic resonance image of the brain. The muted blue areas are regions in which CMRglc was abnormally low only in the E4 carriers. Young adult (30.7 years of age) E4 carriers demonstrate low CMRglc in a pattern similar to probable AD patients, with notable decreases bilaterally in the posterior cingulate, parietal, temporal, and prefrontal cortex. (Figure taken from Reiman et al.¹⁵ Copyright 2004, National Academy of Sciences, U.S.A.; used with permission.)

regions of the cortex. Individual genotypes were examined for differences in CMRglc and none were found. The authors conclude, "Importantly, the extent of hypometabolism did not vary, depending on the APOE genotype in any of the regions of interest in the entire sample or in the patients with AD when they were examined separately."¹⁶ A larger study using 83 subjects with probable AD again found no differences based on presence or absence of the E4 allele.¹⁷ However, studies

using more advanced voxel-based techniques have identified some differences between E4(+) and E4(-) participants. E4(+) subjects may have more global declines in CMRglc, as low rates were detected in other areas of the brain not seen in E4(-) subjects.¹⁸ Thus, some differences may exist between E4 carriers in other regions of the brain or in progression of the CMRglc decline.¹⁹

The molecular cause of the hypometabolism remains unclear. Low CMRglc may be due to alterations in the

processing of either the amyloid precursor protein (App) or the ApoE4 protein. This area has been the subject of many studies and several recent reviews, and the reader is referred to these references for detailed discussion of these models. Mahley and Huang²⁰ have proposed that fragments of the ApoE4 protein escape the normal secretory pathway and enter the mitochondria. Within the mitochondria, the E4 fragments may bind F1-ATPase subunits, thereby reducing cellular energy production (FIG. 2; for review, see reference²⁰). Others have proposed that the Aβ peptide generated from the cleavage of the App protein binds heme leading to a loss of complex

IV activity (FIG. 2; for review, see reference²¹). Still others propose that Aβ peptides stimulate GSK3β activity leading to the phosphorylation of pyruvate dehydrogenase and the inhibition of energy metabolism (FIG. 2, for review see²²). Other studies have indicated that the declines in energy metabolism may be directly due to low expression of energy metabolism genes in affected areas of the brain, such as neurons of the posterior cingulate.²³

However, low rates of CMRglc appear early in the disease well before large amounts of Aβ are predicted to be present, and in AD subjects who are E4(-). There-

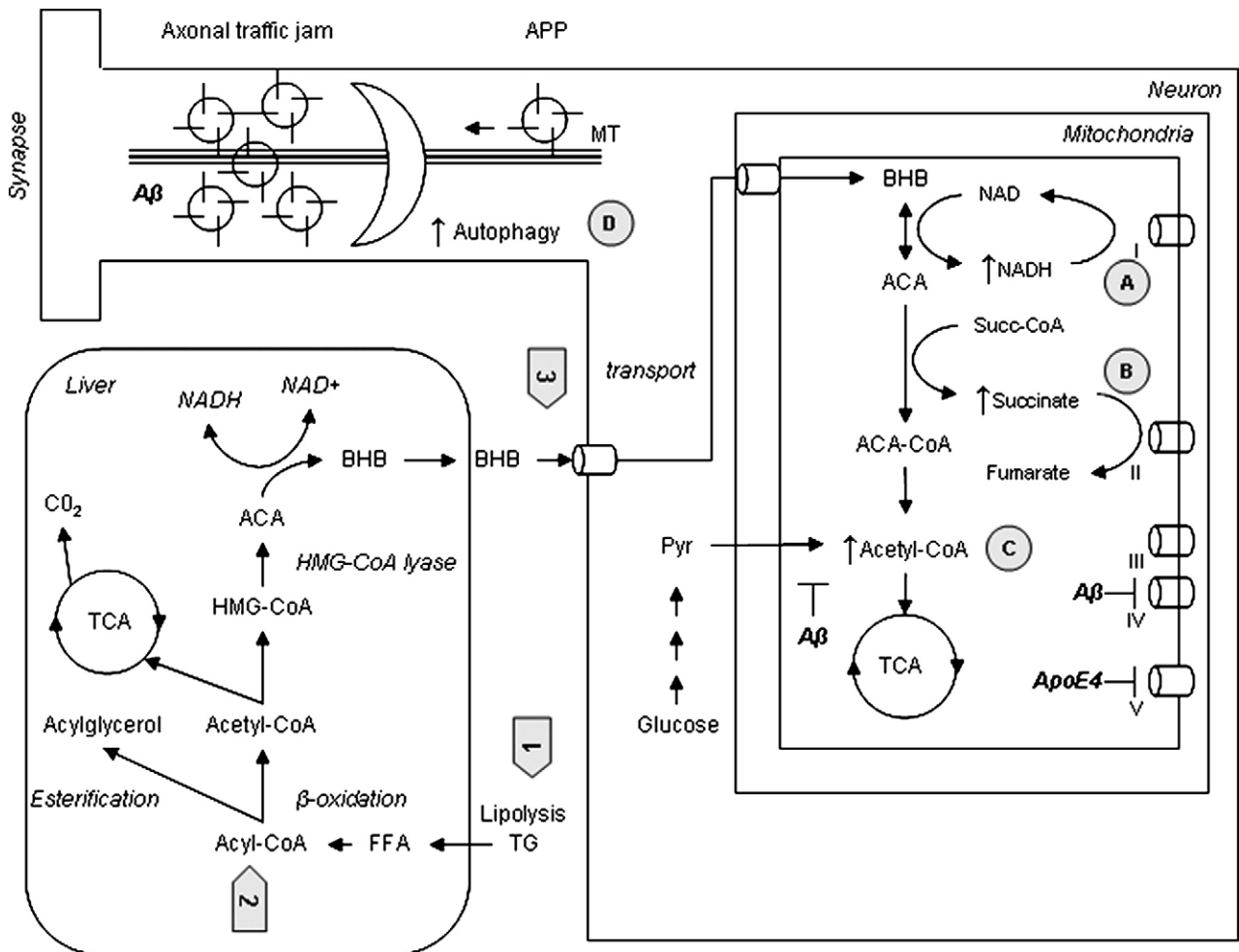

FIG 2. Ketosis and Alzheimer's disease. Ketone bodies are generated in hepatocytes from oxidation of free fatty acids (FFA) in circulation derived from triglyceride (TG) stores. Acetyl-CoA generated from fatty acid oxidation is condensed to form 3-hydroxy-3-methylglutaryl-CoA (HMG-CoA). The action of HMG-CoA lyase removes acetyl-CoA leaving acetoacetate (ACA), which is in equilibrium with β-hydroxybutyrate (BHB) based on the redox state of the nicotinamide adenine dinucleotide (NAD)/NADH couple and catalyzed by D(-)-3-hydroxybutyrate dehydrogenase. Hepatocytes lack the ability to activate ACA to acetoacetyl-CoA, and hence the ACA and BHB are released for use by extrahepatic tissues. Ketogenesis and the use of ketone bodies (KB) are regulated at several key steps, illustrated by shaded block arrows. **1:** Release of FFA from fat stores. **2:** Oxidation or esterification of Acyl-CoA. **3:** Uptake of KB by extrahepatic cells by the amount and activity of monocarboxylate transporters. Metabolic properties of ketone bodies are shown as shaded circled letters. **A:** The BHB converted to ACA generates NADH, thereby reducing the mitochondrial NAD/NADH couple and increasing the oxidation of the co-enzyme Q couple. **B:** Mitochondrial metabolism of ACA increases pool of succinate and **C:** acetyl-CoA. The net effect of these changes is increased metabolic efficiency. **D:** Ketone bodies stimulate chaperone mediated autophagy. Putative deleterious effects of Aβ are shown inhibiting complex IV, inhibiting pyruvate dehydrogenase, and accumulating, as the result of axonal traffic jams. Fragmented apolipoprotein E4 (ApoE4) protein may inhibit complex V. APP = amyloid precursor protein; MT = microtubule; Pyr = pyruvate; Succ = succinate; TCA = the citric acid cycle; TG = triglyceride.

fore, some authors have examined whether disturbances in energy metabolism precede alterations in App processing. Inhibition of energy production by treating cells with sodium azide leads to an 80-fold increase in the generation of an amyloidic C-terminal fragment of App and accumulation of App in the secretory pathway.²⁴ This increase in App fragmentation may be due to increased β -secretase (BACE) activity, the rate-limiting step for A β generation. When wild-type mice were treated with agents that induce acute energy deprivation, such as insulin and 2-deoxyglucose, a long-lasting increase in Bace1 enzyme levels was detected. Elevated Bace1 levels were durable, lasting at least 7 days after treatment. Furthermore, it was found that such treatments led to a 2-fold increase in A β 40 levels 7 days after treatment.²⁵

An alternative hypothesis is that both low CMRglc and altered processing of App are symptoms of a more general disturbance. One possible culprit is alteration in lipid/glucose metabolism induced either by some environmental factor, such as diet, or by genetic predisposition, such as possession of an APOE4 allele, or both. For example, alterations in lipid metabolism that result in low circulating docosahexaenoic acid (DHA) levels may increase the risk of developing AD.²⁶ The disturbances in lipid metabolism may lead to inappropriate cleavage of App and poor functioning of other susceptible proteins such as glucose transporters. The alterations may be evident as hypometabolism, accumulation of amyloid, and the generation of reactive oxygen species. It has been hypothesized that the alterations in lipid metabolism are due to the consumption of modern, evolutionarily discordant diets, and that this is primary to the etiology of AD (for review see reference²⁷).

HYPOMETABOLISM AS THERAPEUTIC TARGET

Regardless of the cause, energy deprivation is harmful to neurons and may contribute substantially to the AD disease process. Therefore, improving the overall cerebral metabolic rate is likely to benefit the AD patient. One way to tackle this problem is to examine how the body normally copes with conditions of low glucose availability and if such conditions may be exogenously applied to AD.

One simple way to examine the response to low glucose availability is through extended fasting or starvation. In classic studies examining brain metabolism during fasting, Owen et al.²⁸ examined the substrate utilization when obese subjects underwent 5 to 6 weeks of complete starvation. During the starvation period, subjects were restricted to one multivitamin capsule, 17 mEq of NaCl, and 1,500 mL of water per day. Rates of glu-

cose synthesis were calculated during the period of starvation. Under such conditions glucose is normally produced predominantly from catabolism of proteins, glycerol from fat stores, or lactate from glycolytic tissues. Based on nitrogen excretion rates and other factors it was estimated that the total glucose synthesized and available to the body during the fast was approximately 33 g of glucose per day, well short of the brains normal oxidation of \sim 110 g per day. Under such starvation conditions, the brain will derive much of its energy needs from the oxidation of ketone bodies (KB). During the starvation, the concentration of the major KB β -hydroxybutyrate was in the range of 4 to 8 mM, 10- to 20-fold over normal fasting values. Cerebral use of metabolic fuels was assessed by catheterization, and it is estimated that under such conditions KB supply about 60% of the brains energy requirements.²⁸

Why use KB during starvation? The primary sources of *de novo* synthesized glucose are amino acids. To provide the high levels of glucose required for the brain would require a significant breakdown of tissue, predominantly muscle. Such loss of lean body mass during periods of food scarcity would likely be maladaptive. Instead, the utilization of KB allows for the tapping of abundant fat stores.²⁸

KB

KB are produced mainly by the liver from fatty acids (FA) during periods of starvation and during neonatal development (FIG. 2). In the adult mammal, ketogenesis and the utilization of KB are regulated at several key steps that prevent substantial amounts of KB from being produced under normal feeding conditions (FIG. 2). Ketogenesis requires abundant circulating free fatty acid (FFA) levels for oxidation in the liver. Thus, conditions such as elevated insulin signaling that limit adipocyte release of FFA, hamper KB production. Once in the hepatocyte, FFA may undergo either oxidation in the mitochondria or re-esterification to triacylglycerols or phospholipids. Carnitine palmitoyltransferase-I (CPT-1) functions to transfer activated FFA into the mitochondria and is a major regulator of the choice between oxidation and esterification. In the nourished state, the presence of insulin signaling inhibits CPT-I, and few KB are produced. In addition, KB may regulate FFA release as part of a feedback loop. β -hydroxybutyrate (BHB) has been demonstrated to activate the receptor HM74a leading to reduced FFA secretion from adipocytes. HM74a is better known as the niacin receptor, a potent lipid-lowering agent. Hence, KB not only have metabolic effects but also act through receptor signaling pathways.²⁹

The regulation of KB production, particularly by carbohydrate in the diet, has consequences in relation to

modern dietary practices. In a normal Western diet, rich in carbohydrates (>50% of total calories consumed), significant ketogenesis is inhibited the vast majority of the time. Significant ketosis is only encountered when dysregulation of insulin signaling has occurred, such as in diabetes. Therefore, ketosis is frequently viewed as an abnormal condition. This is probably an artifact of modern diets. Throughout much of human evolution, ketosis likely served as a valuable survival mechanism to fuel brain metabolism during times of food scarcity.²⁸ Hence, in some ways, the modern diet can be considered “keto-deficient.”

PROPERTIES OF KB

An early clue to the special properties of KB was revealed in the 1940s in experiments testing various metabolites on the motility of sperm. BHB and acetoacetate (ACA) were found to increase sperm motility, while at the same time decreasing oxygen consumption 10 to 29%.^{30,31} This increase in metabolic efficiency has been studied extensively in seminal work done by Veech and colleagues.^{22,32} Working in perfused rat hearts, Sato et al³² found that treatment of cells with levels of KB found during starvation (4 mM BHB and 1 mM ACA)

Table 1. Neuroprotection of Ketogenic Diets and Ketosis

Intervention	Injury	Lesion	Species	Outcome	Reference
Ketogenic diet	Amyotrophic lateral sclerosis	Transgenic SOD1 mouse	Mice	Increased motor neuron counts	41
Ketogenic diet	Traumatic brain injury	Controlled cortical impact	Rats	Reduced contusion volume	42
Ketogenic diet	Alzheimer's disease	Transgenic App expression	Mice	Reduced Abeta levels	44
Ketogenic diet	KA-induced seizures	Kainic acid	Mice	Increased cell survival	62
Ketogenic diet	GLUT1 haploinsufficiency	Glucose deprivation	Human	Decrease seizure frequency	63
Ketogenic diet	Parkinson's disease	Human PD patients	Human	Improved motor function	43
Injection of acetoacetate	Glutamate toxicity	Inhibition of glycolysis by iodoacetate	Rat, cell culture	Neuroprotection	64
Infusion of 4 mM BHB, 5 mM ACA	Glutamate toxicity	Incubation with 5mM glutamate	Cell culture	Increased cell survival	50
Infusion of BHB	Glutamate toxicity	Glutamate and iodoacetate treatment	Rats	Neuroprotection and reduced lipid peroxidation	65
1 mM BHB, 1 mM ACA	Glutamate toxicity	Glutamate treatment	Cell culture	Increased mitochondrial efficiency	66
4 mM BHB	Hypoxia	2-h exposure to hypoxia	Cell culture	Increased cell survival	67
Infusion BHB	Hypoxia	Carotid artery ligation	Mice	Maintained ATP and low lactate	68
Infusion BHB	Ischemia	Occlusion of middle cerebral artery	Mice	Reduced cerebral infarct area	51
Infusion BHB	Traumatic brain injury	Controlled cortical impact	Rats	Restored ATP levels after CCI	69
Ketogenic agent	Alzheimer's disease	Memory problems in Alzheimer's disease	Human	Improved cognitive performance	54
BHB treatment	Alzheimer's disease	Abeta in cell culture model of AD	Cell culture	Increased cell survival	52
BHB infusion	Parkinson's disease	MPTP lesioning	Mice	Improved neuronal survival, improved mitochondrial efficiency	33
BHB treatment	Parkinson's disease	Rotenone treatment of cells	Cell culture	Increased cell survival	70
Dexamethasone treatment	Hypoxia ischemia	3-h episode of hypoxia ischemia	Rats	Neuroprotection	71

ACA = acetoacetate; AD = Alzheimer's disease; BHB = β-hydroxybutyrate; MPTP, 1-Methyl-4-phenyl-1,2,3,6-tetrahydropyridine; App = amyloid precursor protein; KA = kainic acid; GLUT = glucose transporter 1; CCI = controlled cortical impact.

increased cardiac efficiency by 13% compared with control hearts. The increase in metabolic efficiency can be attributed to several key features of KB metabolism (FIG. 2). Briefly, when BHB is converted to ACA it generates NADH (the reduced form of nicotinamide adenine dinucleotide [NAD]), thereby reducing the mitochondrial NAD/NADH couple and increasing the oxidation of the co-enzyme Q couple.³² In addition, KB metabolism increases the mitochondrial pool of acetyl-CoA and succinate.³³ The net effect of these changes is increased metabolic efficiency. The reader is referred to several reviews that extensively cover the metabolic efficiency of KB metabolism.^{22,34,35}

Since KB are normally produced during periods of food deprivation, they may have other survival properties that confer neuroprotection. Interestingly, KB are able to increase rates of chaperone-mediated autophagy. Autophagy (self-eating) is increased when cells are starved of nutrients, in particular amino acids. It is a mechanism in which large cellular structures, such as organelles and foreign bodies, can be delivered to lysosomes for degradation and recycling. Human embryonic fibroblasts treated with 1 to 10 mM BHB demonstrated increased degradation of long-lived proteins and increased autophagic activity. This may occur due to increased oxidation of cellular components by BHB and activation of recycling pathways.³⁶ Autophagy is not limited to starvation conditions and may function under normal conditions to rid cells of damaged or accumulated proteins. This has been found to be particularly useful in neuronal cells. Inhibition of autophagy in several model systems promotes neurodegeneration (for review reference³⁷). Autophagy may be an important mechanism of neurons to clear axonal obstructions such as those that occur in AD.³⁸ However, this model has yet to be tested.

KETOGENIC DIETS

As can be seen by the regulation of KB production, a state of ketosis can be induced by increasing circulating FFA levels and promoting fatty acid oxidation. This can be accomplished by adherence to a ketogenic diet (KD). The KD became of interest in the 1920s when it was developed to reduce seizure frequency in epileptics. This was based on the ancient observation that fasting reduced seizures. In the 5th century, Hippocrates noted that a man suffering from epilepsy was cured by abstaining from all food and drink. The KD was developed to mimic the physiological changes seen in extended fasting. Such diets are very low in carbohydrates and proteins and very high in fat, and have been used successfully for many years to treat refractive childhood epilepsy (for review, see reference³⁹). Importantly, the KD has also been used

successfully to mitigate the symptoms of glucose deprivation, such as those that occur in GLUT1 DS.⁴⁰

The ability of KB to increase mitochondrial efficiency and supplement for glucose makes them attractive compounds to treat AD and other neurological disorders. The KD has demonstrated potential in treating several neurological conditions (see Table 1), including amyotrophic lateral sclerosis,⁴¹ traumatic brain injury⁴² and Parkinson's disease.⁴³ Van der Auwera et al.⁴⁴ reported one of the few studies that directly tested a KD in an animal model of AD. This study used a transgenic line of mice expressing the "London" APP mutation (V717I) driven by the THY1 promoter. These animals exhibit significant levels of soluble A β in as few as 3 months of age, and extensive plaque deposition by 12 to 14 months.⁴⁵ Six-

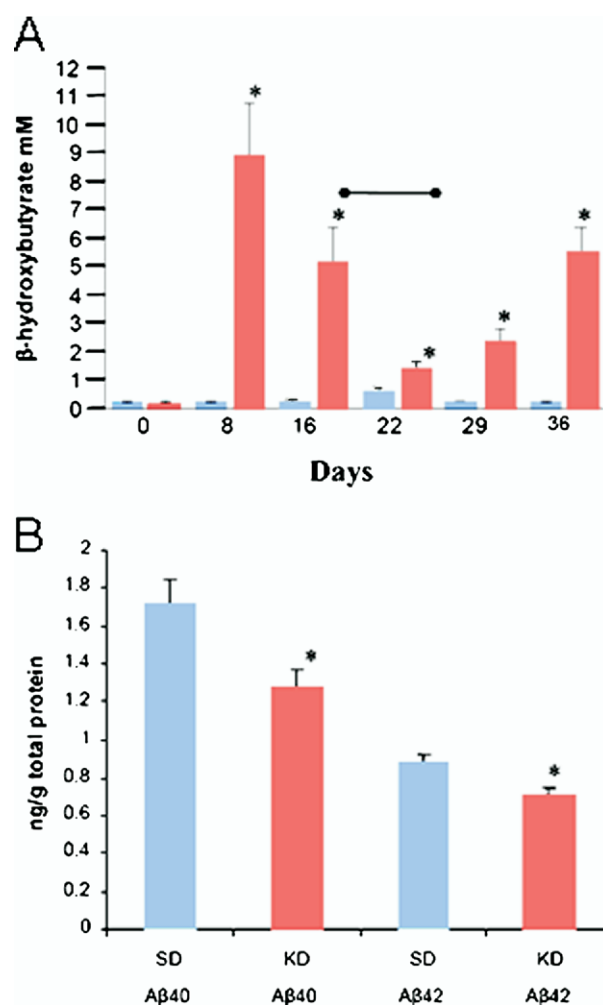

FIG 3. Ketogenic diet in a mouse model of Alzheimer's disease (AD). Ketogenic diet increases circulating ketone bodies and reduces total A β load in mouse model of AD. **A:** Ketogenic chow led to rapid and substantial elevation of serum β -hydroxybutyrate (BHB). Ketogenic chow shown in red, standard chow shown in blue, error bars represent S.E.M. **B:** 43 days after change in diet, levels of both A β 40 and A β 42 were reduced 25%. KD = ketogenic diet; SD = standard diet. *Represents significant *p* values (*p* < 0.05). (Graphs from Van der Auwera et al.⁴⁴; open access article.)

teen, 3-month-old, female mice were fed either a ketogenic chow or standard chow for 43 days. The ketogenic chow consisted primarily of lard and butter fat. It was 79% fat (mostly saturated fats) and less than 1% carbohydrate. The KB levels were significantly elevated during the treatment period ranging from 2 to 9 mM (FIG. 3A). At the end of the treatment, a reduction in both A β 40 and A β 42 levels of 25% was noted (FIG. 3B).⁴⁴ At first, this result may seem at odds with earlier studies that attributed high-fat diets to increased A β loads^{46,47}; however, in these earlier studies, fat was added to the diet without substantial decrease in carbohydrate content. It is unlikely these animals produced KB. The differences in these experimental designs highlight the observation that not all high-fat diets are high-fat diets.⁴⁸

KETOSIS AND AD

The change in macronutrient content in a KD diet from a standard diet induces a set of changes that could contribute to neuroprotective effects, such as reduced glucose, low-insulin signaling, and increased levels of uncoupling proteins.⁴⁹ Several authors have asked if KB alone could mitigate neurodegenerative disorders, including AD. When KB are used in cell culture systems or infused into animal models, numerous reports have indicated neuroprotective qualities (Table 1). For example, infusion of KB into rodents protects them from glutamate toxicity,⁵⁰ ischemia,⁵¹ and 1-methyl-4-phenyl-1,2,3,6-tetrahydropyridine (MPTP) toxicity.³³

This approach has been tested in a cell culture model of AD and in human trials. Exposure of cultured hippocampal cells from 18-day embryonic rats to 5 μ M A β 42 resulted in a 50% decrease in cell number. When

the cells were simultaneously exposed to 4 mM BHB, a doubling of cell survival was observed, suggesting the BHB offers protection from A β toxicity.⁵²

To date, only a single published study has examined the effectiveness of KB treatment in human AD subjects. This study took advantage of the special properties of unique fats called medium chain triglycerides (MCT) to induce ketosis in probable AD subjects. MCT are triglycerides comprised of fatty acid chains between 5 to 12 carbons. Due to the short chain lengths of medium chain fatty acids, MCT are not subject to the regulation imposed on long chain fatty acids. As a result, MCT undergo obligate oxidation. If a sufficiently large quantity of MCT are ingested, the excess acetyl-CoA produced will generate KB (for review of MCT, see reference⁵³). Importantly, the oxidation of MCT occurs regardless of other macronutrients consumed; therefore, administration of MCT differs from a KD in that no restriction of carbohydrate or protein intake is required.

Reger et al.⁵⁴ conducted a crossover study to examine the effects of acute elevation of serum KB levels on cognitive performance in 20 mild to moderate probable AD subjects. A single, 40 g dose of MCT induced a significant elevation (10-fold) of BHB to 0.5 mM after 2 hours. Ninety minutes after dosing, subjects were tested for changes in cognitive performance using the Alzheimer's Disease Assessment Scale-Cognitive subscale (ADAS-Cog), a paragraph recall test, and others. The single administration of MCT led to a significant correlation between performance on the paragraph recall task and serum BHB concentration, with those subjects presenting the highest BHB levels showing the most improvement ($p = 0.02$) (see FIG. 4A). In addition, there was significant improvement in ADAS-Cog scores in

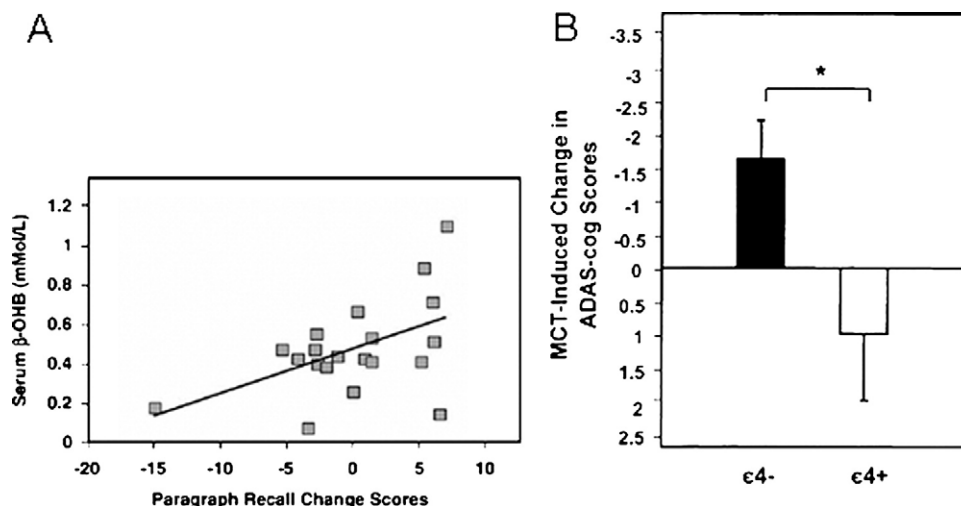

FIG 4. Ketosis in Alzheimer's disease (AD) patients. Medium chain triglycerides (MCT)-induced ketogenesis led to rapid improvement in cognitive tests in a mild to moderate probably AD population. **A:** Serum β -hydroxybutyrate (BHB) levels correlate with improvement in the paragraph recall task ($r = 0.50$; $p = 0.02$). **B:** A 1.5 point improvement in Alzheimer's Disease Assessment Scale-Cognitive subscale (ADAS-cog) scores was observed in APOE4(-) subjects 90 minutes after dosing ($p = 0.039$). Graphs from Reger et al.⁵⁴ (Copyright 2004, Elsevier Inc., used with permission.) β -OHB = β -hydroxybutyrate. * $P < .05$.

subjects who were E4(-), compared with those who were E4(+) ($p = 0.039$) (see FIG 4B). The rapid (90 min) improvement seen in cognitive tasks suggests that the effect is driven by enhanced neuronal metabolism.⁵⁴ A longer, 90-day dosing study has shown similar positive results in E4(-) subjects (Henderson et al., manuscript in preparation). Importantly, the level of ketosis achieved in the Reger et al.⁵⁴ study is considerably lower than those used in infusion studies, and lower than levels predicted for efficacy based on theoretical arguments.²² This suggests that easily achievable levels of ketosis may be beneficial to the AD patient in the absence of dietary changes.

In the Reger et al.⁵⁴ study, efficacy was most notable in E4(-) subjects. Interestingly, APOE4 effects have been noted in other studies targeting the insulin pathway as a treatment for AD. In a series of studies, Craft et al.⁵⁵ found that E4(-) subjects rapidly responded to treatment with glucose and insulin, and when exposed to nasal insulin.⁵⁶ E4 effects were also seen in a larger study with the insulin sensitizing agent rosiglitazone. E4(-) subjects taking an 8 mg dose of rosiglitazone demonstrated a significant difference in ADAS-Cog when compared with placebo scores after 24 weeks. E4(+) subjects show no difference or got slightly worse.⁵⁷

Why would these treatments work preferentially in participants lacking the AD risk factor APOE4? In the rosiglitazone study it was proposed that fragments of ApoE4 protein interfered with mitochondrial function and prevented E4 carriers from responding to PPAR γ activation.⁵⁷ It is possible that such damaged mitochondria also fail to metabolize KB.

An alternative hypothesis relates to differences in insulin sensitivity based on E4 carriage status. In a study of 25 AD subjects, E4(-) carriers were found to have higher fasting insulin levels than normal controls.⁵⁸ This was also observed in the rosiglitazone study.⁵⁷ In a follow-up study of 31 subjects with mild to moderate probable AD, E4(-) subjects were found to have significantly lower glucose disposal rates.⁵⁵ High-fasting insulin and low-glucose disposal rates both suggest that E4(-) subjects are insulin resistant, and correcting this insulin resistant state by administration of insulin either systemically,⁵⁵ nasally,⁵⁴ or by use of the insulin sensitizing agent rosiglitazone⁵⁷ may explain the beneficial effects seen in these studies.

The insulin resistance of E4(-) subjects may also explain their responsiveness to KB, which are relatively impermeable to the BBB and transport into the brain is another factor regulating KB utilization (FIG. 2). KB are transported into the brain by the monocarboxylate transporter (MCTs) carrier proteins. These carrier proteins transport short chain monocarboxylic acids, such as KB and lactate (see reference⁵⁹). MCT1 is widely expressed and found in endothelial cells of the BBB.⁶⁰ The levels of monocarboxylate transporters decrease after weaning

but are known to be elevated in diabetes and in other conditions where insulin resistance occurs, such as prolonged fasting.⁶¹ Mild insulin resistance in E4(-) subjects may increase the levels of MCT1 transporter proteins and allow for better uptake of KB into the brain. However, this mechanism remains to be tested.

CONCLUSION

As the developed world's population ages, the incidence of AD will increase dramatically in the next 40 years. AD will become a serious strain on families, caregivers, and the healthcare system in general. Current treatments are merely palliative and do little to slow the progression of the disease. Yet, a great deal of progress has been made in the understanding of AD and many promising therapies have entered clinical trials. Many exciting therapies are in development, particularly in the areas of A β clearance (e.g., vaccines and passive immunity), or A β prevention (e.g., secretase inhibitors) (see other articles in this issue). Therapies based on KB offer a relatively new area of research in AD and address an early and progressive feature of the disease. Also, KB-based therapies offer the potential for rapid deployment of treatments.

Disclosure

Samuel T. Henderson is an employee of Accera Inc., a company developing ketone body-based therapies for Alzheimer's disease.

Acknowledgments: The author thanks employees of Accera, Inc., Steve Orndorff, Janet Vogel, Linda Barr, Lauren Costantini, Fiona Garvin, and Kurt Vagle, for work on this promising area of Alzheimer's research.

REFERENCES

1. Strittmatter WJ, Roses AD. Apolipoprotein E and Alzheimer's disease. *Annu Rev Neurosci* 1996;19:53-77.
2. Mosconi L, Brys M, Glodzik-Sobanska L, De Santi S, Rusinek H, de Leon MJ. Early detection of Alzheimer's disease using neuroimaging. *Exp Gerontol* 2007;42:129-138.
3. Clarke DD, Sokoloff L. Circulation and energy metabolism of the brain. In: Siegel GJ, Agranoff BW, Albers RW, Molinoff PB, eds. *Basic neurochemistry*. New York: Raven Press, 1994:645-680.
4. Shulman RG, Rothman DL, Behar KL, Hyder F. Energetic basis of brain activity: implications for neuroimaging. *Trends Neurosci* 2004;27:489-495.
5. Raichle ME, Mintun MA. Brain work and brain imaging. *Annu Rev Neurosci* 2006;29:449-476.
6. Buckner RL, Andrews-Hanna JR, Schacter DL. The brain's default network: anatomy, function, and relevance to disease. *Ann N Y Acad Sci* 2008;1124:1-38.
7. Kety SS, Woodford RB, Harmel MH, Freyman FA, Appel KE, Schmidt CF. Cerebral blood flow and metabolism in schizophrenia. The effects of barbiturate semi-narcosis, insulin coma and electroshock. *Am J Psychiatry* 1994;151:203-209.
8. Dwyer DS, Vannucci SJ, Simpson IA. Expression, regulation, and functional role of glucose transporters (GLUTs) in brain. In: Dwyer DS, ed. *Glucose metabolism in the Brain*. London: Academic Press, 2002:159-188.

9. Wang D, Pascual JM, Yang H, et al. Glut-1 deficiency syndrome: clinical, genetic, and therapeutic aspects. *Ann Neurol* 2005;57:111–118.
10. Seidner G, Alvarez MG, Yeh JJ, et al. GLUT-1 deficiency syndrome caused by haploinsufficiency of the blood-brain barrier hexose carrier. *Nat Genet* 1998;18:188–191.
11. de Leon MJ, Ferris SH, George AE, et al. Positron emission tomographic studies of aging and Alzheimer disease. *AJNR Am J Neuroradiol* 1983;4:568–571.
12. Reiman EM, Caselli RJ, Yun LS, et al. Preclinical evidence of Alzheimer's disease in persons homozygous for the epsilon 4 allele for apolipoprotein E. *N Engl J Med* 1996;334:752–758.
13. Small GW, Ercoli LM, Silverman DH, et al. Cerebral metabolic and cognitive decline in persons at genetic risk for Alzheimer's disease. *Proc Natl Acad Sci U S A* 2000;97:6037–6042.
14. Buckner RL, Snyder AZ, Shannon BJ, et al. Molecular, structural, and functional characterization of Alzheimer's disease: evidence for a relationship between default activity, amyloid, and memory. *J Neurosci* 2005;25:7709–7717.
15. Reiman EM, Chen K, Alexander GE, et al. Functional brain abnormalities in young adults at genetic risk for late-onset Alzheimer's dementia. *Proc Natl Acad Sci U S A* 2004;101:284–289.
16. Corder EH, Jelic V, Basun H, et al. No difference in cerebral glucose metabolism in patients with Alzheimer disease and differing apolipoprotein E genotypes. *Arch Neurol* 1997;54:273–277.
17. Hirono N, Hashimoto M, Yasuda M, et al. The effect of APOE epsilon4 allele on cerebral glucose metabolism in AD is a function of age at onset. *Neurology* 2002;58:743–750.
18. Mosconi L, Nacmias B, Sorbi S, et al. Brain metabolic decreases related to the dose of the ApoE e4 allele in Alzheimer's disease. *J Neurol Neurosurg Psychiatry* 2004;75:370–376.
19. Lehtovirta M, Kuikka J, Helisalmi S, et al. Longitudinal SPECT study in Alzheimer's disease: relation to apolipoprotein E polymorphism. *J Neurol Neurosurg Psychiatry* 1998;64:742–746.
20. Mahley RW, Huang Y. Apolipoprotein (apo) E4 and Alzheimer's disease: unique conformational and biophysical properties of apoE4 can modulate neuropathology. *Acta Neurol Scand Suppl* 2006;185:8–14.
21. Atamna H, Frey WH, 2nd. Mechanisms of mitochondrial dysfunction and energy deficiency in Alzheimer's disease. *Mitochondrion* 2007;7:297–310.
22. Veech RL, Chance B, Kashiwaya Y, Lardy HA, Cahill GF, Jr. Ketone bodies, potential therapeutic uses. *IUBMB Life* 2001;51:241–247.
23. Liang WS, Reiman EM, Valla J, et al. Alzheimer's disease is associated with reduced expression of energy metabolism genes in posterior cingulate neurons. *Proc Natl Acad Sci U S A* 2008;105:4441–4446.
24. Gabuzda D, Busciglio J, Chen LB, Matsudaira P, Yankner BA. Inhibition of energy metabolism alters the processing of amyloid precursor protein and induces a potentially amyloidogenic derivative. *J Biol Chem* 1994;269:13623–13628.
25. Velliquette RA, O'Connor T, Vassar R. Energy inhibition elevates beta-secretase levels and activity and is potentially amyloidogenic in APP transgenic mice: possible early events in Alzheimer's disease pathogenesis. *J Neurosci* 2005;25:10874–10883.
26. Calon F, Cole G. Neuroprotective action of omega-3 polyunsaturated fatty acids against neurodegenerative diseases: evidence from animal studies. *Prostaglandins Leukot Essent Fatty Acids* 2007;77:287–293.
27. Henderson ST. High carbohydrate diets and Alzheimer's disease. *Med Hypotheses* 2004;62:689–700.
28. Owen OE, Morgan AP, Kemp HG, Sullivan JM, Herrera MG, Cahill GF, Jr. Brain metabolism during fasting. *J Clin Invest* 1967;46:1589–1595.
29. Taggart AK, Kero J, Gan X, et al. (D)-beta-Hydroxybutyrate inhibits adipocyte lipolysis via the nicotinic acid receptor PUMA-G. *J Biol Chem* 2005;280:26649–26652.
30. Lardy HA, Hansen RG, Phillips PH. The metabolism of bovine epididymal spermatazoa. *Arch Biochem* 1945;6:41–51.
31. Lardy HA, Phillips PH. Studies of fat and carbohydrate oxidation in mammalian spermatazoa. *Arch Biochem* 1945;6:53–61.
32. Sato K, Yoshihiro K, Keon CA, et al. Insulin, ketone bodies, and mitochondrial energy transduction. *Faseb J* 1995;9:651–658.
33. Tieu K, Perier C, Caspersen C, et al. D-beta-hydroxybutyrate rescues mitochondrial respiration and mitigates features of Parkinson disease. *J Clin Invest* 2003;112:892–901.
34. Gasior M, Rogawski MA, Hartman AL. Neuroprotective and disease-modifying effects of the ketogenic diet. *Behav Pharmacol* 2006;17:431–439.
35. Prins ML. Cerebral metabolic adaptation and ketone metabolism after brain injury. *J Cereb Blood Flow Metab* 2008;28:1–16.
36. Finn PF, Dice JF. Ketone bodies stimulate chaperone-mediated autophagy. *J Biol Chem* 2005.
37. Martinez-Vicente M, Cuervo AM. Autophagy and neurodegeneration: when the cleaning crew goes on strike. *Lancet Neurol* 2007;6:352–361.
38. Stokin GB, Goldstein LS. Axonal transport and Alzheimer's disease. *Annu Rev Biochem* 2006;75:607–627.
39. Freeman J, Veggiotti P, Lanzi G, Tagliabue A, Perucca E. The ketogenic diet: from molecular mechanisms to clinical effects. *Epilepsy Res* 2006;68:145–180.
40. Klepper J, Scheffer H, Leiendecker B, et al. Seizure control and acceptance of the ketogenic diet in GLUT1 deficiency syndrome: a 2- to 5-year follow-up of 15 children enrolled prospectively. *Neuropediatrics* 2005;36:302–308.
41. Zhao Z, Lange DJ, Voustantiok A, et al. A ketogenic diet as a potential novel therapeutic intervention in amyotrophic lateral sclerosis. *BMC Neurosci* 2006;7:29.
42. Prins ML, Fujima LS, Hovda DA. Age-dependent reduction of cortical contusion volume by ketones after traumatic brain injury. *J Neurosci Res* 2005;82:413–420.
43. Vanitallie TB, Nonas C, Di Rocco A, Boyar K, Hyams K, Heymsfield SB. Treatment of Parkinson disease with diet-induced hyperketonemia: a feasibility study. *Neurology* 2005;64:728–730.
44. Van der Auwera I, Wera S, Van Leuven F, Henderson ST. A ketogenic diet reduces amyloid beta 40 and 42 in a mouse model of Alzheimer's disease. *Nutr Metab (Lond)* 2005;2:28.
45. Moechars D, Dewachter I, Lorent K, et al. Early phenotypic changes in transgenic mice that overexpress different mutants of amyloid precursor protein in brain. *J Biol Chem* 1999;274:6483–6492.
46. Ho L, Qin W, Pompl PN, et al. Diet-induced insulin resistance promotes amyloidosis in a transgenic mouse model of Alzheimer's disease. *Faseb J* 2004;18:902–904.
47. Levin-Allerhand JA, Lominska CE, Smith JD. Increased amyloid levels in APPSWE transgenic mice treated chronically with a physiological high-fat high-cholesterol diet. *J Nutr Health Aging* 2002;6:315–319.
48. Feinman RD. When is a high fat diet not a high fat diet? *Nutr Metab (Lond)* 2005;2:27.
49. Sullivan PG, Rippey NA, Dorenbos K, Concepcion RC, Agarwal AK, Rho JM. The ketogenic diet increases mitochondrial uncoupling protein levels and activity. *Ann Neurol* 2004;55:576–580.
50. Noh HS, Hah YS, Nilufar R, et al. Acetoacetate protects neuronal cells from oxidative glutamate toxicity. *J Neurosci Res* 2006;83:702–709.
51. Suzuki M, Suzuki M, Kitamura Y, et al. Beta-hydroxybutyrate, a cerebral function improving agent, protects rat brain against ischemic damage caused by permanent and transient focal cerebral ischemia. *Jpn J Pharmacol* 2002;89:36–43.
52. Kashiwaya Y, Takeshima T, Mori N, Nakashima K, Clarke K, Veech RL. D-beta-hydroxybutyrate protects neurons in models of Alzheimer's and Parkinson's disease. *Proc Natl Acad Sci U S A* 2000;97:5440–5444.
53. Bach AC, Babayan VK. Medium-chain triglycerides: an update. *Am J Clin Nutr* 1982;36:950–962.
54. Reger MA, Henderson ST, Hale C, et al. Effects of beta-hydroxybutyrate on cognition in memory-impaired adults. *Neurobiol Aging* 2004;25:311–314.
55. Craft S, Asthana S, Schellenberg G, et al. Insulin effects on glucose metabolism, memory, and plasma amyloid precursor protein in Alzheimer's disease differ according to apolipoprotein-E genotype. *Ann N Y Acad Sci* 2000;903:222–228.

56. Reger MA, Watson GS, Frey WH, 2nd, et al. Effects of intranasal insulin on cognition in memory-impaired older adults: modulation by APOE genotype. *Neurobiol Aging* 2006;27:451–458.
57. Risner ME, Saunders AM, Altman JF, et al. Efficacy of rosiglitazone in a genetically defined population with mild-to-moderate Alzheimer's disease. *Pharmacogenomics J* 2006;6:246–254.
58. Craft S, Peskind E, Schwartz MW, Schellenberg GD, Raskind M, Porte D, Jr. Cerebrospinal fluid and plasma insulin levels in Alzheimer's disease: relationship to severity of dementia and apolipoprotein E genotype. *Neurology* 1998;50:164–168.
59. Halestrap AP, Price NT. The proton-linked monocarboxylate transporter (MCT) family: structure, function and regulation. *Biochem J* 1999;343(Pt 2):281–299.
60. Froberg MK, Gerhart DZ, Enerson BE, et al. Expression of monocarboxylate transporter MCT1 in normal and neoplastic human CNS tissues. *Neuroreport* 2001;12:761–765.
61. Robinson AM, Williamson DH. Physiological roles of ketone bodies as substrates and signals in mammalian tissues. *Physiol Rev* 1980;60:143–187.
62. Noh HS, Kim YS, Lee HP, et al. The protective effect of a ketogenic diet on kainic acid-induced hippocampal cell death in the male ICR mice. *Epilepsy Res* 2003;53:119–128.
63. Klepper J, Leiendecker B. GLUT1 deficiency syndrome—2007 update. *Dev Med Child Neurol* 2007;49:707–716.
64. Massieu L, Haces ML, Montiel T, Hernandez-Fonseca K. Acetoacetate protects hippocampal neurons against glutamate-mediated neuronal damage during glycolysis inhibition. *Neuroscience* 2003;120:365–378.
65. Mejia-Toiber J, Montiel T, Massieu L. D-beta-hydroxybutyrate prevents glutamate-mediated lipoperoxidation and neuronal damage elicited during glycolysis inhibition in vivo. *Neurochem Res* 2006;31:1399–1408.
66. Maalouf M, Sullivan PG, Davis L, Kim DY, Rho JM. Ketones inhibit mitochondrial production of reactive oxygen species production following glutamate excitotoxicity by increasing NADH oxidation. *Neuroscience* 2007;145:256–264.
67. Masuda R, Monahan JW, Kashiwaya Y. D-beta-hydroxybutyrate is neuroprotective against hypoxia in serum-free hippocampal primary cultures. *J Neurosci Res* 2005;80:501–509.
68. Suzuki M, Suzuki M, Sato K, et al. Effect of beta-hydroxybutyrate, a cerebral function improving agent, on cerebral hypoxia, anoxia and ischemia in mice and rats. *Jpn J Pharmacol* 2001;87:143–150.
69. Prins ML, Lee SM, Fujima LS, Hovda DA. Increased cerebral uptake and oxidation of exogenous beta HB improves ATP following traumatic brain injury in adult rats. *J Neurochem* 2004;90:666–672.
70. Imamura K, Takeshima T, Kashiwaya Y, Nakaso K, Nakashima K. D-beta-hydroxybutyrate protects dopaminergic SH-SY5Y cells in a rotenone model of Parkinson's disease. *J Neurosci Res* 2006;84:1376–1384.
71. Dardzinski BJ, Smith SL, Towfighi J, Williams GD, Vannucci RC, Smith MB. Increased plasma beta-hydroxybutyrate, preserved cerebral energy metabolism, and amelioration of brain damage during neonatal hypoxia ischemia with dexamethasone pretreatment. *Pediatr Res* 2000;48:248–255.